



ASSEMBLY INSTRUCTION

Model : D12DC / VEG2BDSC-N





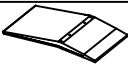

Description : Dining Chair

Thank you for purchasing this quality product. Be sure to check all packing material carefully for small parts that may have come loose inside the carton during shipment.

PART LIST:

No.	Description	Diagram	Quantity
A	Chair Back		1
B	Seat cushion		1
C	Chair Leg		2

HARDWARE LIST:

No.	Description	Diagram	size	Quantity
D	Bolt		Ø5/16" x 3-1/4"	4
E	Bolt		Ø5/16" x 2-1/4"	4
F	Bolt		Ø5/16" x 1-1/2"	2
G	Lock Washer		Ø5/16"	10
H	Flat Washer		Ø5/16"	10
I	Allen Key		M5	1

Step 1: Use the bolt (F), lock washer (G) and flat washer (H) to assemble the seat cushion (B) on the chair back (A), after that squeeze by allen key (I)

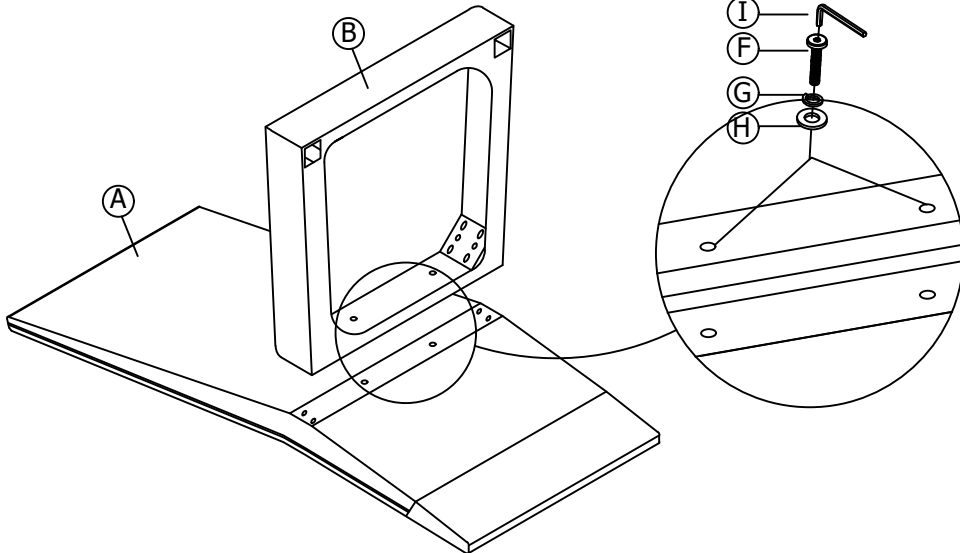

Step 2: Use the bolt (D), lock washer (G) and flat washer (H), after that squeeze by allen key (I)

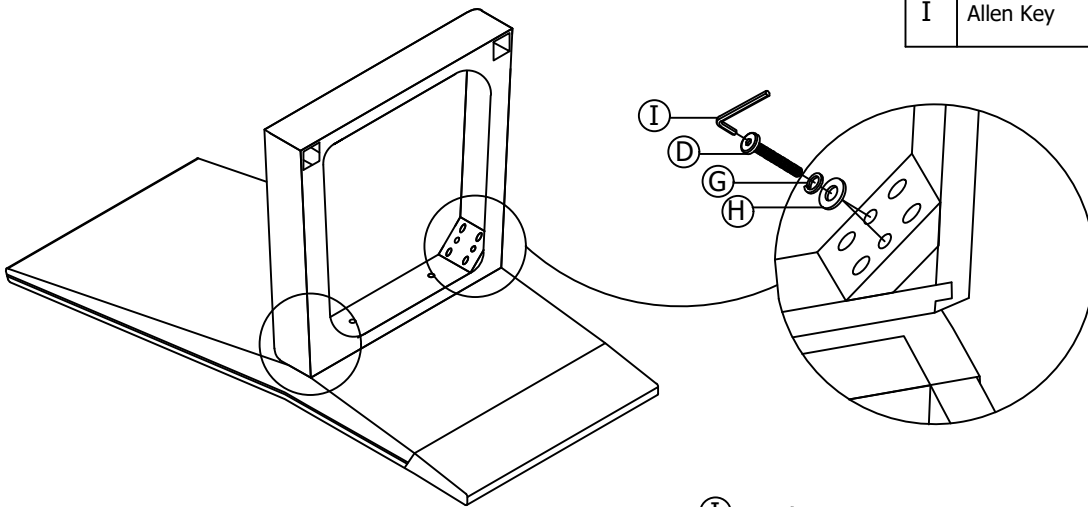

Step 3: Use the bolt (E), lock washer (G) and flat washer (H) to assemble the chair leg (C) on the seat cushion (B), after that squeeze by allen key (I)

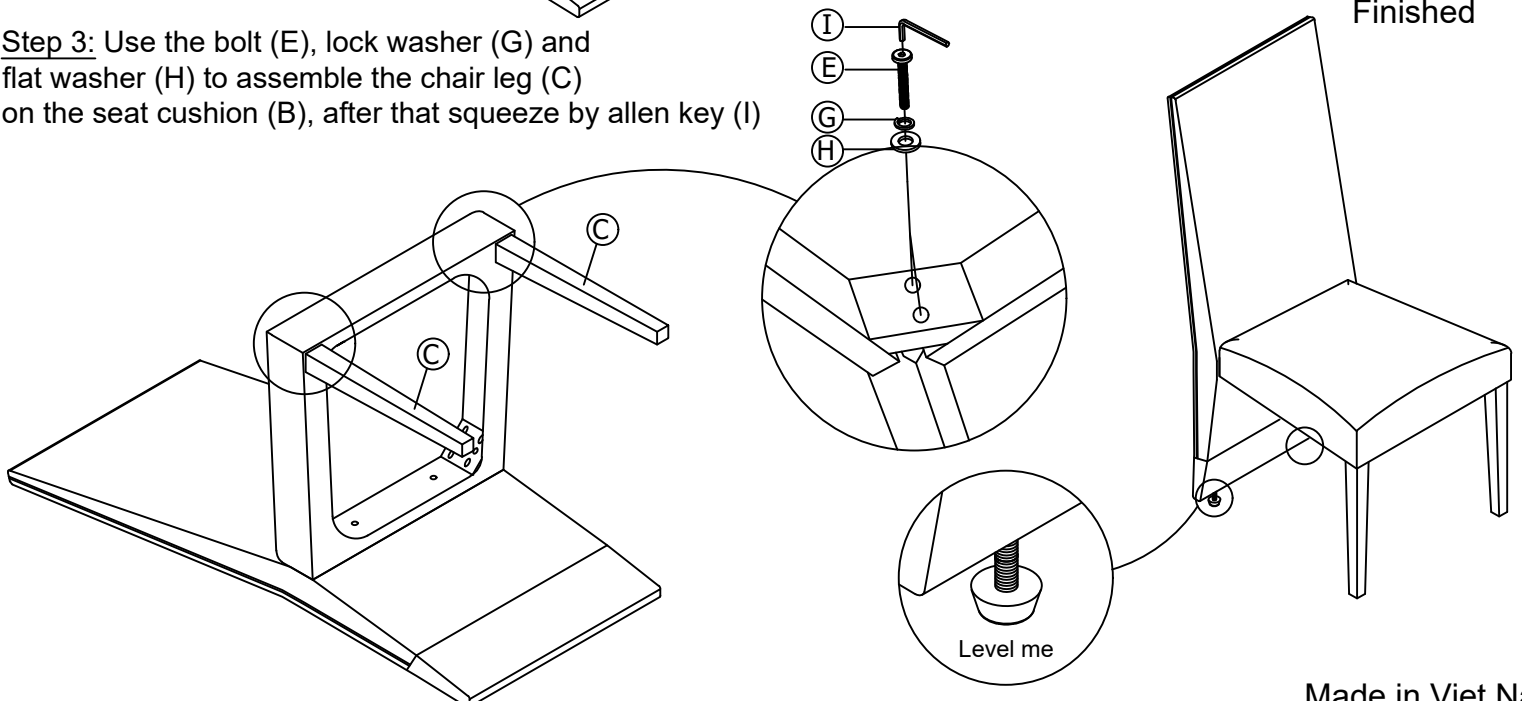

Made in Viet Nam

INSTRUCTIONS DE MONTAGE

Modèle : D12DC / VEG2BDSC-N

Description : Chaise de salle à manger

Merci d'avoir acheté ce produit de qualité. Assurez-vous de vérifier soigneusement tout le matériel d'emballage pour petites pièces qui peuvent s'être détachées à l'intérieur du carton pendant le transport.

Étape 1 : Utilisez le boulon (F), la rondelle de blocage (G) et la rondelle plate (H) pour assembler le coussin du siège (B) sur le dossier de la chaise (A), puis serrez avec la clé allen (I)

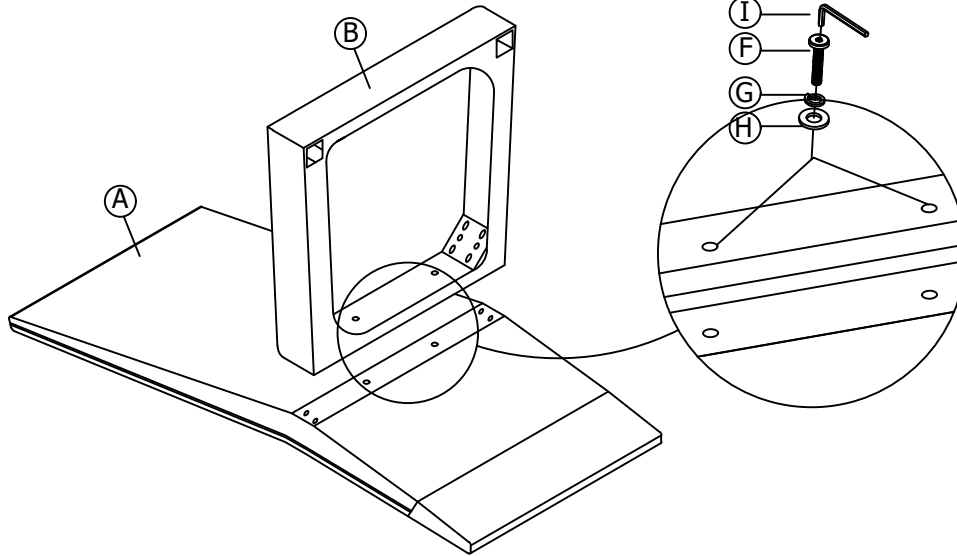

LISTE DES PIÈCES:

Nombre	Description	Graphique	Quantité
A	Dossier de chaise		1
B	Coussin de siege		1
C	Pied de chaise		2

LISTE DU MATÉRIEL :

Nombre	Description	Graphique	La taille	Quantité
D	Boulon		Ø5/16" x 3-1/4"	4
E	Boulon		Ø5/16" x 2-1/4"	4
F	Boulon		Ø5/16" x 1-1/2"	2
G	Rondelle frein		Ø5/16"	10
H	Rondelle plate		Ø5/16"	10
I	Clé Allen		#5	1

Étape 2 : Utilisez le boulon (D), la rondelle frein (G) et la rondelle plate (H), après cela, pressez la clé Allen (I)

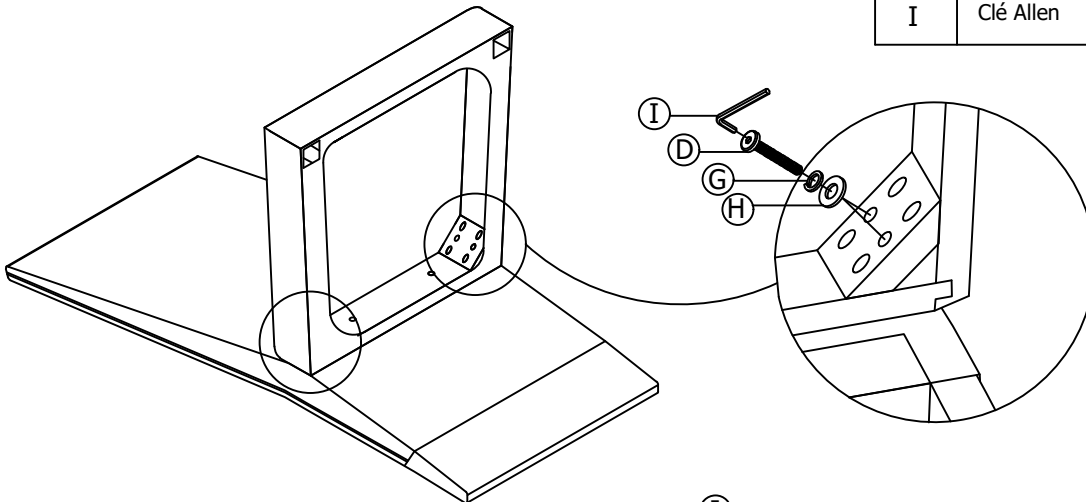

Étape 3 : Utilisez le boulon (E), la rondelle de blocage (G) et rondelle plate (H) pour assembler le pied de chaise (C) sur le coussin du siège (B), puis serrez avec la clé allen (I)

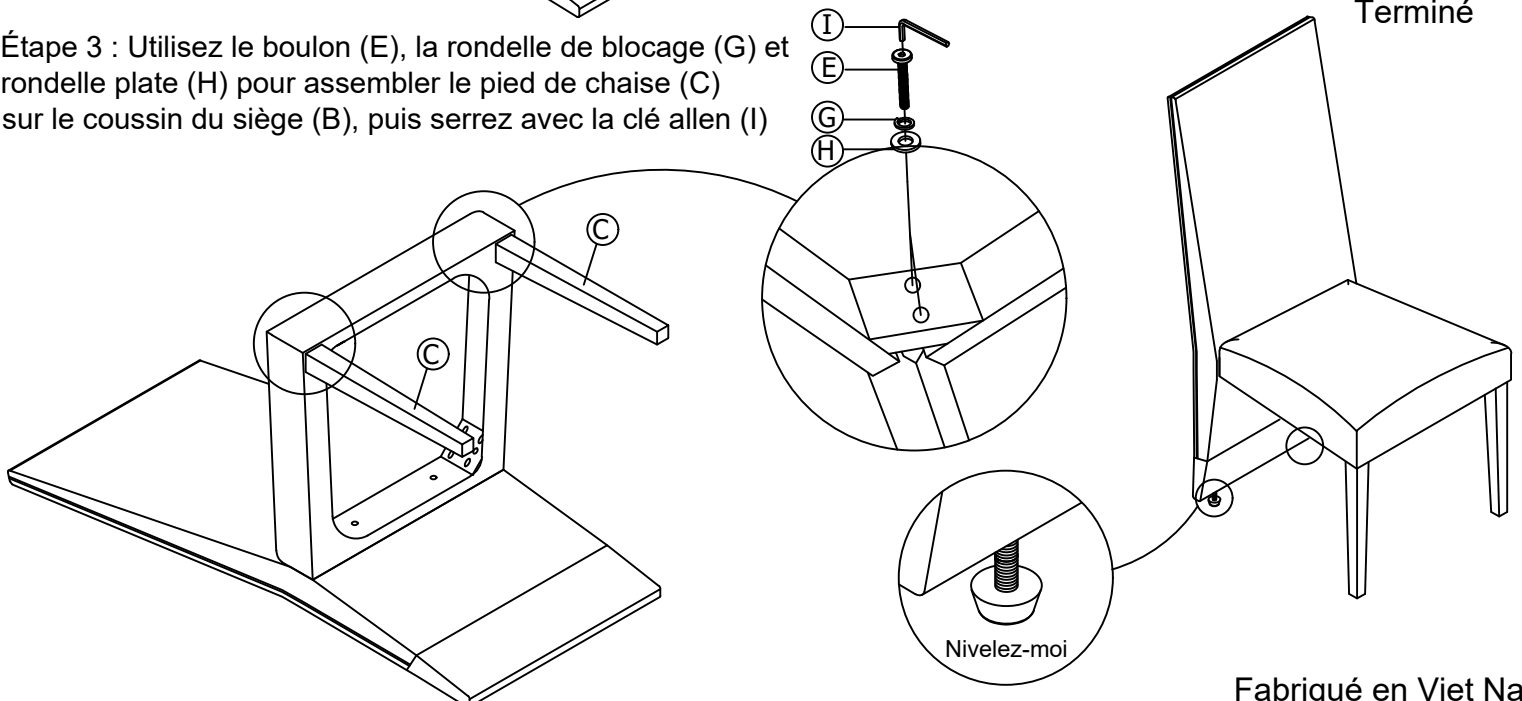

Fabriqué en Viet Nam