

ASSEMBLY INSTRUCTIONS NOTICE D'ASSEMBLAGE

SARAWDSC/EKS240848 SHARE-111 SARAADSC/EKS240848 SHARE-315
SARAGDSC/EKS240848 SHARE-460

Important note/Note importante:

1. Kindly follow the assembly instructions step by step./ Veuillez suivre la notice d'assemblage, pas à pas.
2. Do not tighten all screws and bolts until the chair is fully assembled./ Ne serrer les vis et boulons à fond que lorsque le produit est entièrement assemblé.

PARTS IDENTIFICATION / IDENTIFICATION DES PIÈCES

1 seat/siège

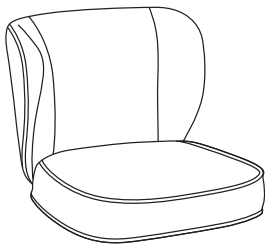

1pc

2 leg/pied

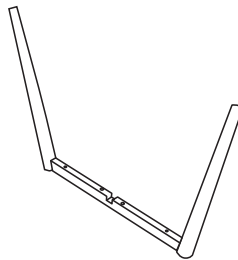

1pc

3 leg/pied

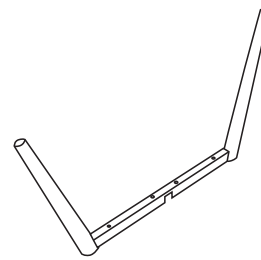

1pc

HARDWARE IDENTIFICATION / IDENTIFICATION DES PIÈCES MONTAGE

A Screw/Vis

M6x40mm



4pcs

B Screw/Vis

M6x60mm



4pcs

C Bolt Boulon

M6



8 pcs

D Screw gasket/Vis de serrage du joint

M6x16x1.5mm



4pcs

E Allen Key Clé Allen

M6x14x1mm



4pcs

F Allen Key Clé Allen

M4



1pc

G cross plate plaque transversale

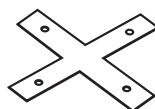

1pc

H cross plate plaque transversale

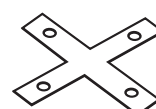

1pc

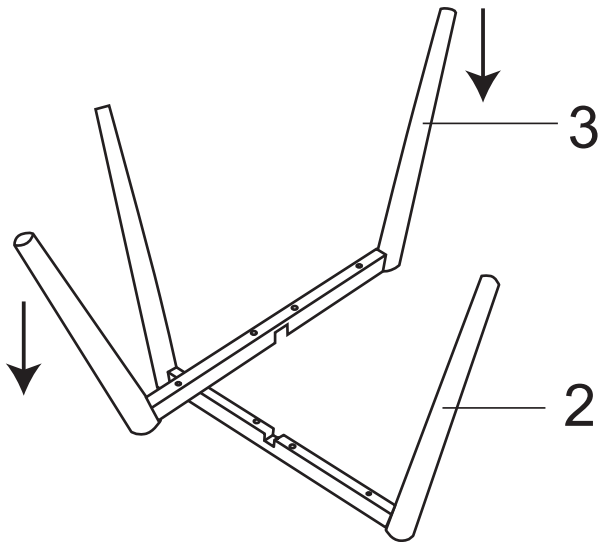
STEP 1 / ÉTAPE 1**STEP 2 / ÉTAPE 2**

STEP 2 : 50% tighten screw at this stage.
ÉTAPE 2 : À ce stade, serrer la vis à 50%.

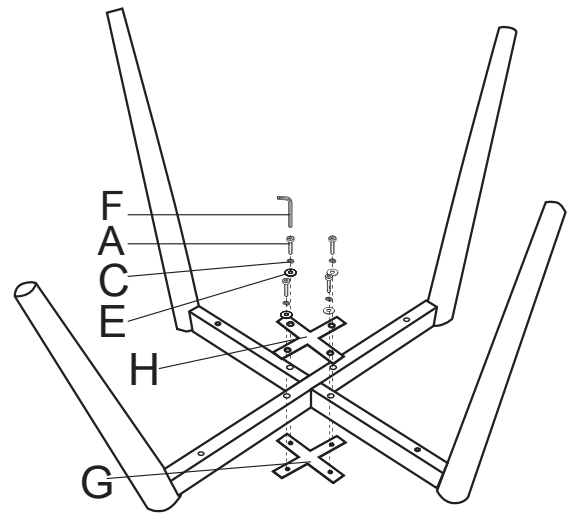
**STEP 3 / ÉTAPE 3**

STEP 3 : After all parts are in right position, then 100% tighten up all screws before using.
ÉTAPE 3 : Avant l'utilisation, une fois toutes les pièces à la bonne place, serrez toutes les vis à 100%.

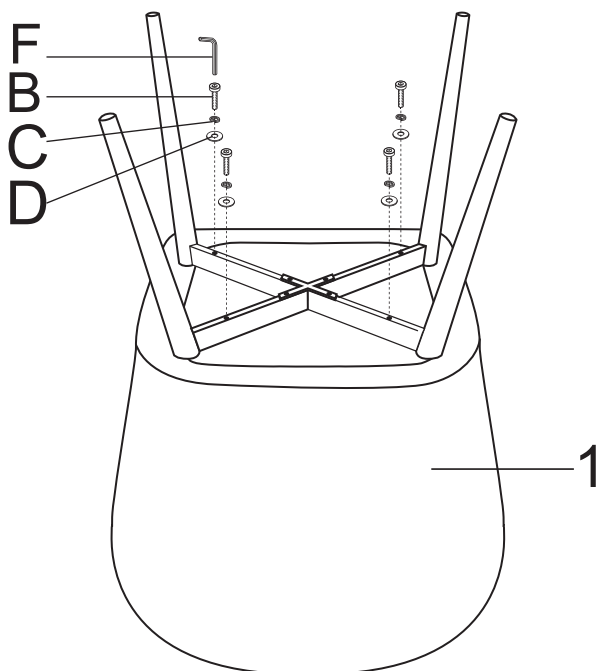
**COMPLETE / ASSEMBLAGE TERMINÉ**