



MAGNUSSEN[®]
H O M E
Bringing dreams home.

ASSEMBLY INSTRUCTIONS

MODEL:T4852-31

Step 1

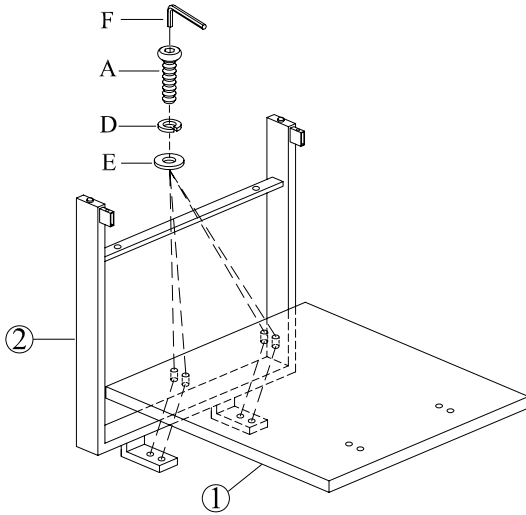

Step 2

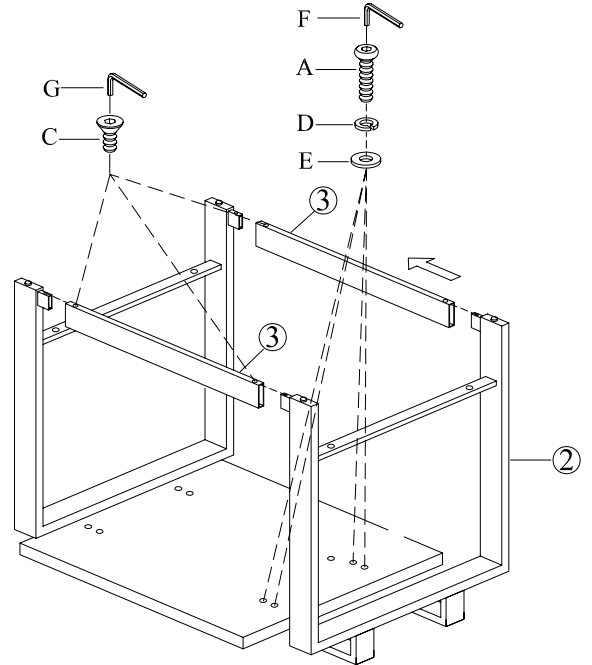

Step 3

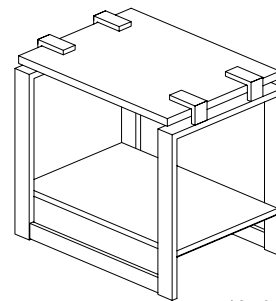
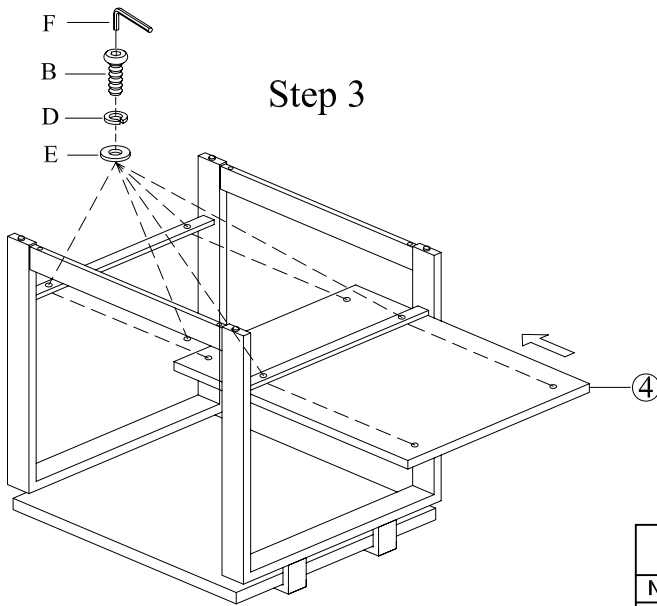

T4852-31

LIST OF PARTS AND HARDWARE:

No.	Description	Q'ty
A	Bolt Ø5/16"*1-1/2"	8 PCS
B	Bolt Ø5/16"*7/8"	4 PCS
C	Head Bolt Ø1/4"*5/8"	4 PCS
D	Lock Washer Ø5/16"	12 PCS
E	Flat Washer Ø5/19" *16	12 PCS
F	Allen Wrench 5mm	1 PC
G	Allen Wrench 4mm	1 PC

LIST OF PARTS AND HARDWARE:

No.	Description	Q'ty
1	Top	1 PC
2	Side Panel	PT4852-31 PA 2 PCS
3	Bottom Stretcher	PT4852-31 SR 2 PCS
4	Bottom Shelf	PT4852-31 SH 1 PC

NOTE:

ASSEMBLE UNIT ON A SOFT SURFACE.

ASSEMBLEZ L'UNITÉ SUR UNE SURFACE MOLLE.

ENSAMBLE LA UNIDAD EN UNA SUPERFICIE PLANA Y SUAVE.

DO NOT TIGHTEN BOLTS UNTIL THE UNIT IS COMPLETELY ASSEMBLED.

NE SERREZ PAS LES BOULONS JUSQU'À CE QUE L'UNITÉ SOIT COMPLÈTEMENT ASSEMBLÉE.

NO APRIETE LOS TORNILLOS HASTA QUE LA UNIDAD ESTE COMPLETAMENTE ENSAMBLADA.