









## ASSEMBLY INSTRUCTIONS (INSTRUCTIONS D'ASSEMBLAGE)

### HARDWARE LIST (LISTE DES OUTILS):

NO. NO.	Sketch Schéma	Description Description	Qty Qté
1		Bolt(1/4"*7/8") Boulon	6 PCS 6 PCES
2		Bolt(1/4"*1-1/4") Boulon	12 PCS 12 PCES
3		Spring Washer(1/4") Rondelle frein	18PCS 18PCES
4		Washer(1/4") Rondelle plate	18 PCS 18PCES
5		Allen wrench(4mm) Clé hexagonale	1 PC 1 PCE

### PARTS LIST (LISTE DES PIECES):

NO. NO.	Sketch Schéma	Description Description	Qty Qté
A		Table top Dessus de table	1 PC 1 PCE
B		Wing Panel Panneau latéral	2 PCS 2 PCES
C		Pedestal Piédestale	2 PCS 2 PCES
D		Base Ring Anneau de base	1 PC 1 PCE

### Step 1 / Étape 1

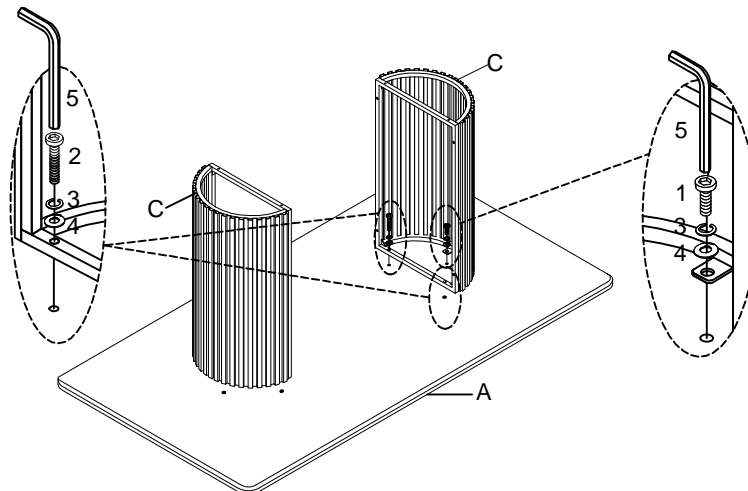

Note: At this stage, do not fully tighten the bolts .  
À noter qu'il ne faut pas serrer complètement les boulons à ce stade.

### Step 2

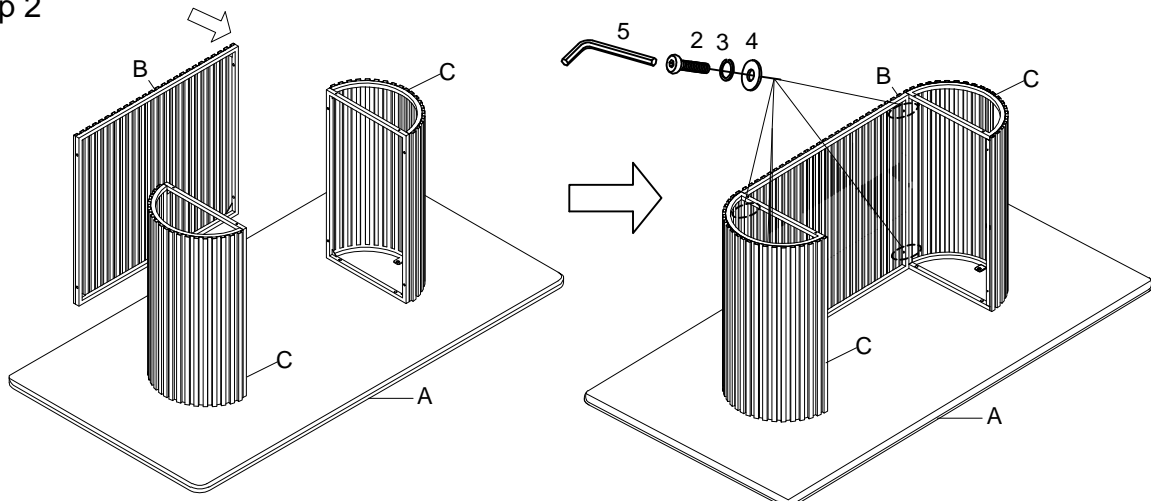

Note: At this stage, do not fully tighten the bolts .  
À noter qu'il ne faut pas serrer complètement les boulons à ce stade.

## ASSEMBLY INSTRUCTIONS (INSTRUCTIONS D'ASSEMBLAGE)

### Step 3

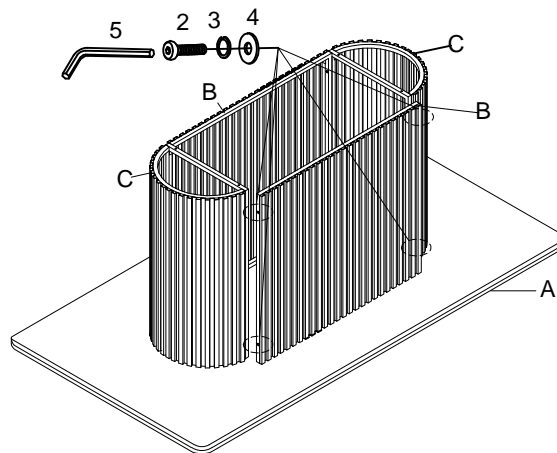

Note: At this stage, do not fully tighten the bolts .

À noter qu'il ne faut pas serrer complètement les boulons à ce stade.

### Step 4

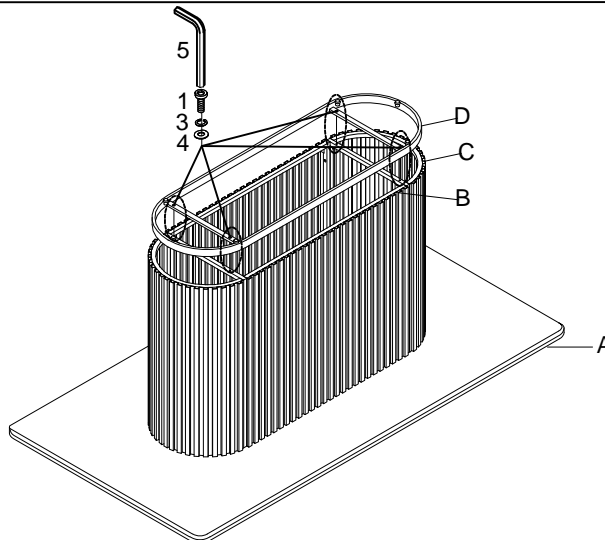

Note: At this stage, do not fully tighten the bolts .

À noter qu'il ne faut pas serrer complètement les boulons à ce stade.

### Step 5

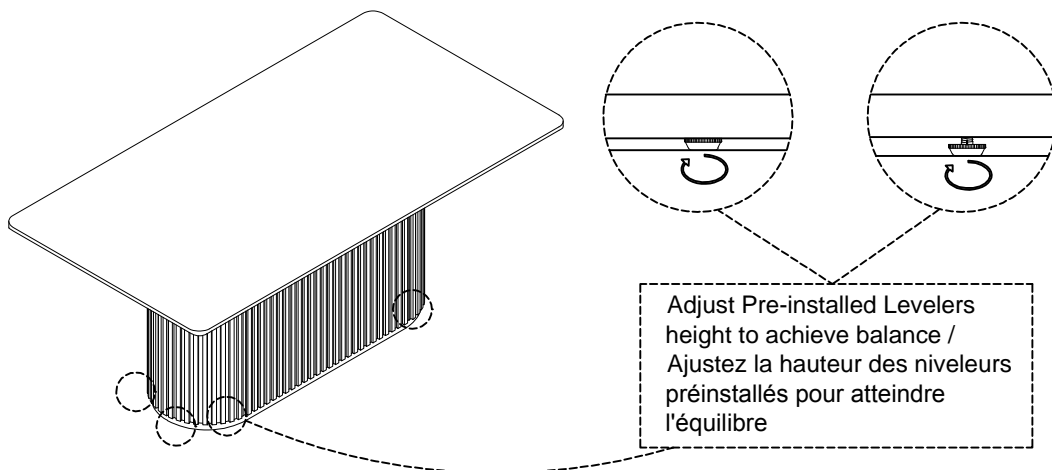

Note: Fully tighten all bolts at this step.

Serrer complètement tous les boulons à cette étape.