

ASSEMBLY INSTRUCTIONS / NOTICE D'ASSEMBLAGE

ITEM: WM#3110-DC/ASTRBDSC

Important note/ Note importante:

1. Place all wooden parts on a clean and smooth surface such as a rug or carpet to avoid scratching the parts. / Placer les pièces sur une surface propre et lisse tel qu'une couverture ou un tapis pour éviter d'endommager les pièces.
2. Kindly follow the assembly instructions step by step./ Veuillez suivre la notice d'assemblage, pas à pas.
3. Do not tighten all screws and bolts until the table is fully assembled./ Ne serrer les vis et boulons à fond que lorsque le produit est entièrement assemblé.
4. Unscrew the protective plastic supports from the metal insert of the legs before assembly./ Dévisser les caches plastiques des embouts métalliques des pieds de la table avant l'assemblage.

PARTS IDENTIFICATION / IDENTIFICATION DES PIÈCES

A Chair Back
Dossier



2pcs

B Leg
with label " R / ↑"
Patte
avec étiquette " D / á "



2pcs

C Leg
with label " L / ↑"
Pied
avec étiquette " G / á "



2pcs

D Front Stretcher / Back Stretcher
Barreau avant / Barreau arrière

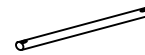

4pcs

HARDWARE IDENTIFICATION / IDENTIFICATION DES PIÈCES MONTAGE

1 Bolt
Boulon
Ø1/4"x30mm



12pcs

2 Spring Washer
Rondelle D'arrêt
Ø1/4" x12mm



12pcs

3 CKS C/B Screw
Vis de type C/B, série CKS
M4 x38mm

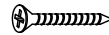

8pcs

4 Allen Key
Clé Allen
M4 x100mm



1pc

STEP 1 / ÉTAPE 1

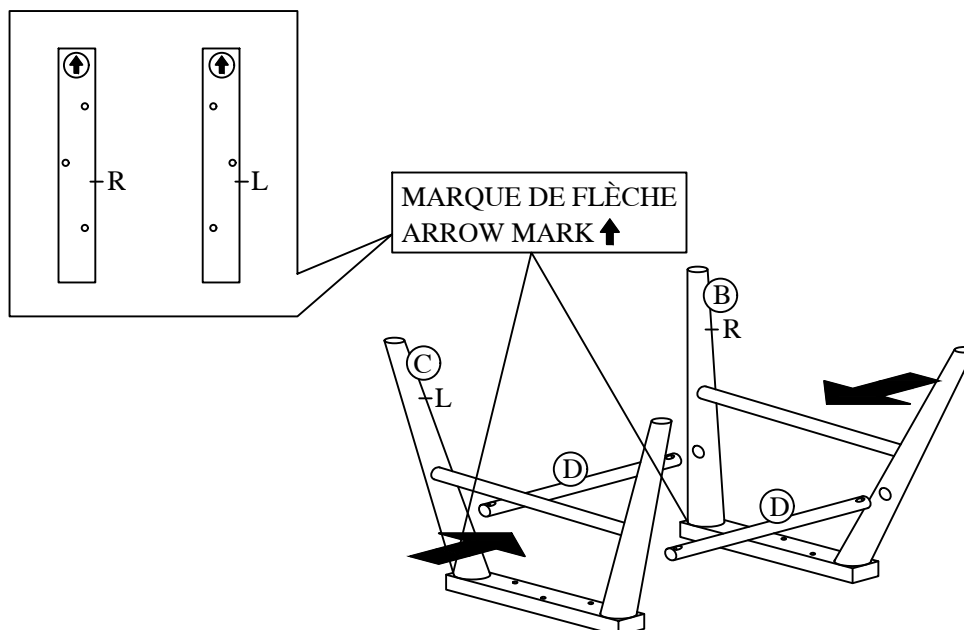

ASSEMBLY INSTRUCTIONS / NOTICE D'ASSEMBLAGE

ITEM: WM#3110-DC/ASTRBDSC

STEP 2 / ÉTAPE 2

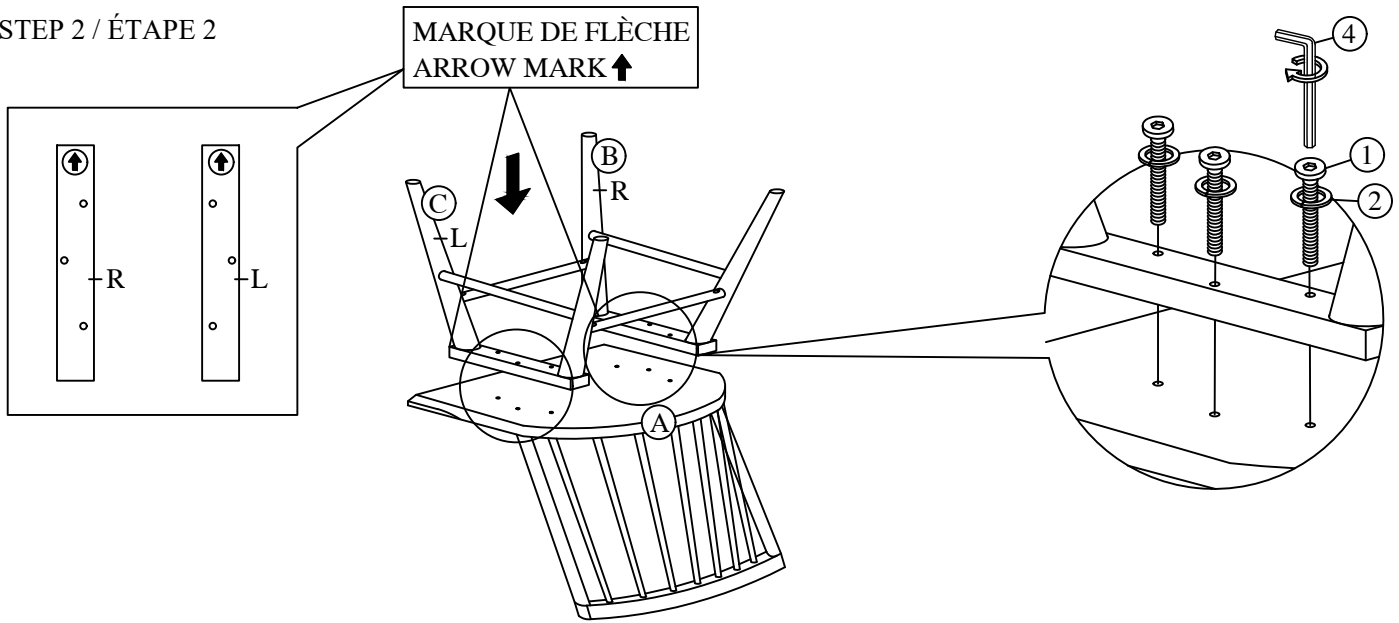

STEP 3 / ÉTAPE 3

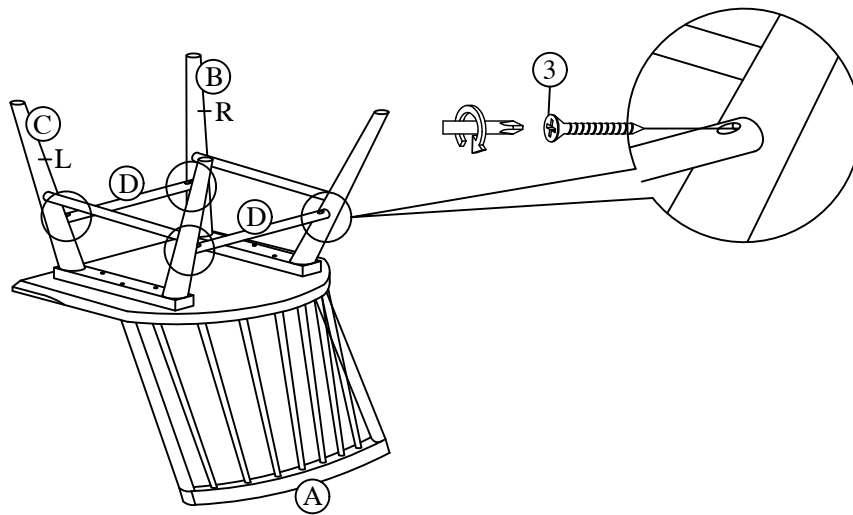

COMPLETE

